



## 2009 ANNUAL REPORT



### A NOTE FROM THE EXECUTIVE DIRECTOR

*Just after the festive season, when everybody is evaluating and assessing the past 2009, I find it difficult to let it go – it was a good and long year, and definitely seemed longer than 365 days. For us it meant hard work, new colleague, and many new endeavours, about which you will be able to read in this report. One of the things heavily discussed among us is when we help more – when we slowly push the system to change or when we help individuals. We will never reach an agreement on this question, but we are happy to do both and to be lucky enough to witness successes on individual children and in the environment which gets more supportive each day. Sometimes, to measure our advocacy achievements in decades can be rather discouraging. Imagine, if we were selling refrigerators – for ten years we would have sold hundreds of thousands of them, and – given our energy and motivation – probably have been inventing some new forms of freezing food. But then, even if it is only little, measured in numbers and tangibles, it is actually big in shifting people’s thinking, understanding and attitude.*

*2008 was good, 2009 was better and 2010 seems even brighter and more interesting. And we will go with the revolution – together with you, we hope.*

*Yours,*

*Iva Boneva*

# Inclusive EDUCATION

**All Means All – Promoting Models and Approaches in Education that Will Lead to a School for All** is the

name of a new project, financed by the Global Opportunities Fund of the Foreign and Commonwealth Office of the United Kingdom. We are now working with children, teachers and parents supporting the complete inclusion of children with special educational needs from primary and secondary education. In 2010 we will publish materials, write articles and raise awareness on positive practices of inclusion - thus slowly, but steadily changing public attitudes towards inclusion for all.



## **EMBED - Embedding Dyslexia-Responsive Practices in Lifelong Learning**

continued into 2009. Many of its results can be seen at <http://www.embeddyslexia.eu/>. It is an international project, involving Hungary, Poland, United Kingdom, Italy and Spain, which supports the dyslexic individuals all over Europe. We are the Bulgarian Representative.

On November 14th, 2009, with the generous support of Vivacom and together with Vivacom we hosted a Round Table on Dyslexia Related Policies in Europe and Bulgaria, which was very successful, attended beyond expectations and very fruitful. Our partners and specialists in the field of inclusive education from the United Kingdom, Italy, Spain and Hungary presented policies and the support that their governments provide to individuals with dyslexia. As a result of the discussions the international team together with us and other Bulgarian specialists from around the country made a list with recommendations towards our government for embedding successful policies and practices, that support people with dyslexia.



## **GATE - understanding dyslexia phenomena between pre-primary and primary school**



GATE is the name of a new EACEA funded project that we started this autumn. We are the Bulgarian partner. On the basis of recent scientific studies on dyslexia, the GATE project objective is to develop a methodology and related operational materials for:

- \* the identification of pupils at risk of dyslexia in pre-primary schools
- \* provision of specific support to those pupils in pre-primary and primary schools.

The project will then focus on vertical continuity between pre-primary and primary schools in providing support to pupils at risk of dyslexia.

The methodology and operational materials to be developed will mainly target pre-primary and primary teachers but will also foster the communication between teachers and families. Parents, in fact, will play a central role in communicating between pre-primary and primary teachers. The final beneficiaries will be pupils aged from 4 to 7, i.e. those passing from pre-primary to primary school.

The project will also create European network on the topic (GATE Network) aiming at involving all relevant stakeholders for the promotion of project results and of the adoption of the GATE system (the final project product) in pre-primary and primary schools across Europe. For the GATE system exploitation, an operative scheme targeting school Principals

will also be developed. We hope that this project will help many teachers, parents and students in Bulgaria, Italy, Spain, Luxemburg, Turkey and Scotland.

### **A CHANCE: Integrated Approach for Early Prevention of Children's Asocial Behaviour and Dropping out of School**

is the name of a new project, led by IGA Fund from Pazardzik, where we partner. Its main aim is to create a truly integrated approach into the prevention of the child asocial behaviour trough introducing a set of interventions that can identify and eliminate risk factors that can lead to such behaviour. It also aims to help children who already behave improperly.

The project aims to meet, talk and work with 120 children in 67 School in Sofia. We also plan to train teachers, meet parents and work together to ensure more children will have normal childhood and will live in a less risky environment.



# CHILD PROTECTION

**Keeping Children Safe** project ended in 2009, uniting several nongovernmental organizations, who work in the field of child protection into an informal network. It introduced the International Standards "Keeping Children Safe" to fourteen Bulgarian NGOs and formed a group of trainers, who later spread the project activities over seven regions in Bulgaria. The main focus was on developing capacities of nongovernmental and community based organisations as well as local authorities who provide direct services for children. Minimum standards for child protection were used as useful tool to prevent violence against their daily operations and

The project also provided for cooperation between governmental child protection. State well as the Agency for role in the successful well as for the planning of

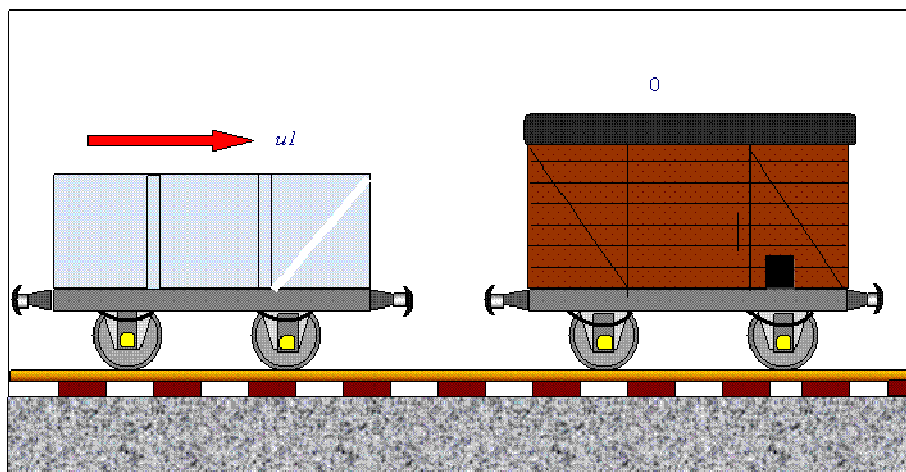

children and were introduced in organizational procedures.

newer and more opportunities nongovernmental and organizations in the field of Agency for Child Protection, as Social Support played a crucial completion of the project as the next one.

**Keeping Children Safe Wherever They Are project.** During the course of the current project it became obvious that it is essential that all local stakeholders (not just NGOs, but also Institutions for children deprived of parental care, Schools, Municipalities) introduce systems to recruit staff appropriately, address poor practice and behaviour, respond to

child protection concerns when they arise and have a proper communication with each other and the Child Protection Departments and Juvenile delinquency police departments and juvenile judges in order to solve challenging cases.

Therefore, the main goal of the new project that just started in October is to create a working model for appropriate rapid reaction to child abuse cases on local level. It started in four municipalities and the work will be based on the international "Keeping Children Safe" standards for Child Protection by non-governmental and governmental structures that work directly with children.

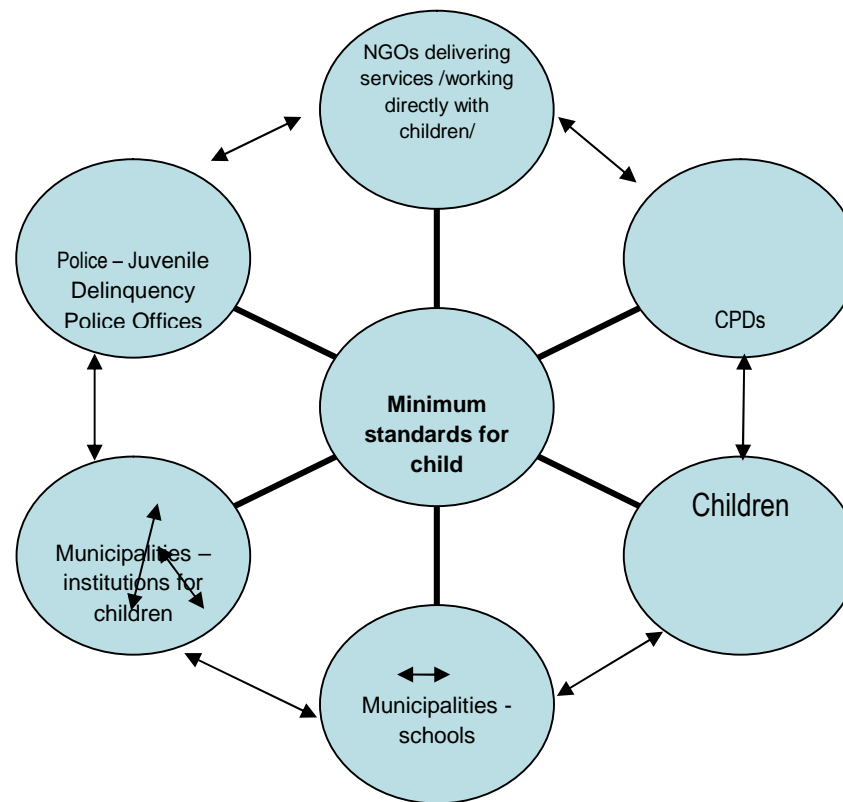

**Comprehensive Response to On-line Child Sexual Abuse and Exploitation** was successfully completed in June.

It was implemented in partnership by the Center for Inclusive Education and Save the Children Norway – SEE Regional Office with the financial support of the OAK foundation. It did lay the foundations of strengthening the system for prevention of online sexual exploitation of children in Bosnia and Herzegovina and Bulgaria.

We  
and Poland  
prevention of  
exploitation  
The report  
future  
broadly  
a Round table in Radisson in May.



conducted a study which identified good practices in Bulgaria and that presented an overview of the existing system for online sexual abuse and of children in Bulgaria. suggested recommendations for action, which were shared and discussed at

The discussion organized by CIE had all major stakeholders in Bulgaria (institutions as well as NGOs and children) involved in working for prevention and fight with child pornography and online exploitation who discussed, identified and agreed upon the most urgent measures to be taken in the near future to ensure a safer cyberspace for children. Although not so acute yet, the problem of child pornography on Bulgarian websites is gradually gaining speed. In the year to come, more joint actions are foreseen.





# CHILD PARTICIPATION

Although most NGOs in Bulgaria which work for improving child welfare system recognise that it should be a guiding principle when working with children that they need to participate in discussions and decisions that concern them, this still happens rarely. Much remains to be done until the voices of all children, especially the most vulnerable, are heard.

Child participation is about influencing decision-making and achieving change. It is an informed and willing involvement of all children including those who are differently able and those at risk, in any matter concerning them either directly or indirectly. Children's participation is a value that cuts across all programmes and can take place in all arenas – from homes to government, from local to international levels. A short project, funded by OAK in the autumn 2009 was just a small, but important step in teaching how this can be done. Our team had the opportunity to learn from Gerison Landsdown and Sam Harris and later on to pass this knowledge to Bulgarian NGOs who work with vulnerable children.



# GETTING OTHERS IN THE KNOW

## Alan Heath and Ian Smythe training Bulgarian professionals, teachers and parents



In October we hosted again **Mr Alan Heath**, who delivered three lectures on Auditory processing and Sensory integration for parents and teachers. Alan is uniquely qualified in the field of education. He is an Educational Kinesiology - Brain Gym ®

Instructor and Consultant, he is Neuro Linguistics which is the and learn. He has run trainings across the UK and Europe.



also a qualified Practitioner of study of how our minds work for thousands of teachers



In March **Dr Ian Smythe**

an international consultant working in the field of literacy development and specific learning difficulties in different language and cultural environments.

delivered two lectures for parents and teachers. He is

## Our renowned seminars and workshops continued throughout 2009

Our team continued the well known now series of trainings specially designed to help parents and



specialists working with children with learning difficulties to better understand the needs and build on the strengths of the child. Most requested among them were the following:

- ⚙ Inclusive Education and SEN
- ⚙ Dyslexia
- ⚙ Hyperactivity/ Attention deficit – recognizing and
- ⚙ The pedagogy and therapy of Maria Montesori
- ⚙ Index for Inclusion



# FINANCE

## FINANCIAL INCOME

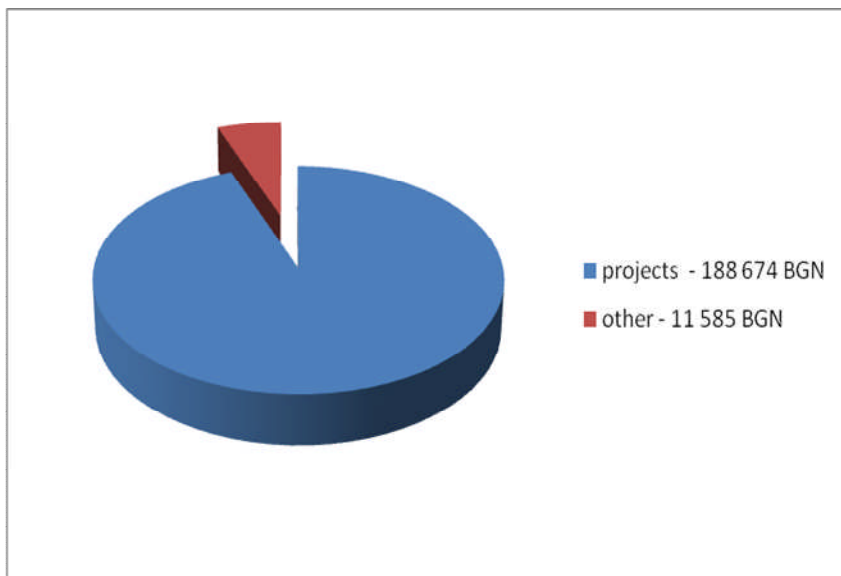

## EXPENCES

